



Design of an Arduino UNO-based Automatic Light Control System as a Basic Physics Teaching Aid on Ohm's Law

Zhahrotun Nurroniah¹, Nadiah Putri Anggraeni², I'man Hadi Asy'ari³
Devita Syafa Adisti Putri⁴, Safina Aulia Sani⁵ Alex Harijanto⁶, Subiki⁷

^{1,2,3,4,5}Mahasiswa Universitas Jember

^{6,7}Dosen Universitas jember

Abstract

Received: 21 Juni 2023

Revised: 29 Juni 2023

Accepted: 03 Juli 2023

Arduino UNO design is a series that is carried out through processes to make automatic lights by designing, making device prototypes, implementing, and testing the final device until the device is complete and ready to be tested. The purpose of this research is to develop a prototype of basic physics teaching aids on the subject of Ohm's law. The method used in this research is the research and development method. The results obtained in this study are that the Arduino uno-based automatic light control circuit can be used as a basic physics teaching aid for Ohm's law material. This trainer uses 4 lights that are assembled in series and parallel. In addition, this trainer is accompanied by Bluetooth to connect with an Android smartphone as a light switch controller.

Keywords: Props, Arduino Uno, Ohm's Law

(*) Corresponding Author: zhahrotun6@gmail.com

How to Cite: Nurroniah Z, Anggraeni N.P., Asy'ari I.H., Putri D.S.A, Sani S.A, Harijanto A, & Subiki. (2023). Design of an Arduino UNO-based Automatic Light Control System as a Basic Physics Teaching Aid on Ohm's Law. <https://doi.org/10.5281/zenodo.8160171>

INTRODUCTION

The development of technology that is increasingly advanced makes a lot of progress that is so fast that it must be utilized, studied, as well as applied in everyday life. One of the advances that can be felt in the field of education today is being able to develop various combinations of learning media used (Kurniadi & Fitriyani, 2015). In addition to explaining the material, learning media as one of the supports in the learning process can be in the form of laboratory tools and materials. In other words, tools and materials can be an important device to be included in the learning process. The selection of tools and materials becomes a basic construction in finding precise data, such as in practicum. Through this learning process, experiments in higher education require several supporting tools to achieve the objectives of the desired material concept (Susanti & Asmoro, 2019). This is in line with research conducted by Subekti & Ariswan (2016) explaining that the experimental method is a way of presenting subjects that involve students being able to actively learn and prove the material they learn themselves so that they can prove and draw conclusions related to objects that can later be applied, especially in physics.

Current developments in the instrumental field can be in the form of sensors, microcontrollers, and computers that make it possible to build a simple instrument that is more accurate and portable (Kadir, 2013). In addition, the important thing that needs to be done from the existence and availability of this

sensor is to be able to combine existing sensors and be able to operate them to be applied with instrument modules such as the application of infrared sensors and Arduino Uno for simple teaching aids on the subject of free fall motion to detect the frequency of vibration of objects (Qomariyah et al., 2020).

Among the courses in the Physics Education Study Program, University of Jember, one of them is the Basic Physics Experiment course. As the name implies, the course does direct practice to prove some of the previous theories that already exist. One of the materials discussed in the basic Physics experiment course is the ohm's law experiment. The concept developed in this experiment is to train skills in using physics measuring instruments and to understand the concepts put forward by George Simon Ohm (March 16, 1789 - July 6, 1854), a physicist from Germany. So as to support the implementation of this course, a teaching aid is needed. Teaching aids are tools whose function is used to visualize the concept of physics or can be as a measuring tool in conducting practicum activities. The use of teaching aids in learning can certainly optimize to increase the effectiveness of learning by seeing, feeling, and using it logically (Widiyatmoko & Pamelasari, 2012). In addition, the existence of teaching aids can help clarify a physics concept with a deeper understanding during direct learning. This is in line with the research of Nuvitalia, *et al* (2016) which states that the function of teaching aids is to facilitate the objectives of implementing learning. Where teaching aids must be able to channel messages and stimulate thoughts so that they can encourage learning. Of course, the use of creative teaching aids will be easier to improve the quality of learning.

Ohm's Law discusses the relationship between electric current, resistance, and voltage. Before understanding the relationship between these two physical quantities, it is necessary to know the definition of electric current and voltage. Electric current is the amount of electric charge that flows unit time. while the direction of the electric current can be interpreted as the direction of the movement of positive charges or protons. In metals made from conductors, the moving charge is negative so that the direction of the electric current is opposite to the direction of movement of the electric charge (Saefullah et al., 2018). The movement of electric charge occurs when there is a potential difference so that electrons will move from low potential to high potential. Where in a circuit a voltage is needed to produce the electric current itself by installing a power supply or battery. The existing electric charge moves through the wires of the circuit from one battery terminal to another terminal. The experiment conducted by George Simon Ohm is the amount of electric current in a conductor is directly proportional to the resulting voltage. The ease with which electric current flows in an electrical conductor depends on the type of conductor. Where the conductor's ability to flow electric current is called conductivity, the opposite of resistivity can be referred to as resistance (R). Where the greater the resistivity of a conductor, the more difficult it will be for electric current to pass through ($1-\frac{1}{R}$). In other words, the relationship between voltage, electric current, and resistance can be written mathematically as follows.

$$I = \frac{V}{R}$$

Some research related to Ohm's law using microcontrollers, namely research conducted by (Aslam et al., 2016) can show a graph of the relationship between voltage and current directions in the discussion of "Development of graph-based Ohm's Law Practical Tools Using Microcontrollers on Physics Teacher Candidates". According to (Aslam et al., 2016), the ability to illustrate graphs here can be a requirement demanded in physics learning because it can display and help analyze the relationship between existing variables. Not only that, but graphs can also explain a concept practically and more efficiently so that it will make it easier to understand physics concepts from existing measuring instruments. Other research related to Ohm's law is research conducted by Djatmiko (2017) which states that a voltage divider circuit with 2 resistors connected to the Arduino uno R3 board can be utilized as a digital resistance meter. So that the resistance value can be known through Arduino sketch-based calculations in the form of resistance data from the reading of one resistor displayed on the 20x4 character LCD module.

In line with this, the use of teaching aids in the ohm law circuit can be used to improve understanding of existing material concepts. So in other words, learning innovations in the development of teaching aids need to be further developed so that educators can easily convey material. Learning updates are needed to keep up with the times by maintaining the main mission of educating the nation's life. Of course, the development of information technology in the current global era has a major impact on all areas of life, including the field of education itself (Muchlis & Toifur, 2017). Based on this, the researchers developed teaching aids for basic physics learning on Ohm's law in Arduino Uno-based automatic light control.

METHODS

The method used in this research is the research and development method. This method aims to produce knowledge, applications, and products with the latest innovations. In research and development (R&D) research, the method of designing tools is done starting with field studies to find existing problems. Then proceed with designing the tool through the design of the props that have been made, after which it begins at the stage of preparing the series of props. At the last stage of this research, the props were tested. This research has the following flow.

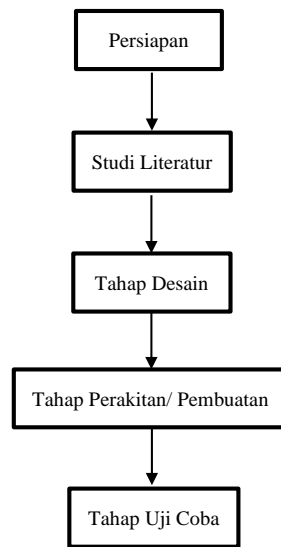

Figure 1. Research flow

a. Preparation

At this stage, the researcher identifies the problem, then proceeds to formulate the problem. In addition, prepare the tools and materials needed. The components used in making the design of teaching aids are as follows.

- 1) Arduino UNO, functions as an electronic program maker component
- 2) 2 channel relay module, functions as a switch to turn on the lights
- 3) HC-05 Bluetooth module, functions as a connector for props to smartphones in controlling lights automatically
- 4) Jumper cable, which serves as a connector for electronic components other than Arduino to the breadboard
- 5) Light fittings, serves as a link between lights and electricity
- 6) 5V lamp, serves as an indicator of circuit output
- 7) Box X6, serves as a container for the Arduino circuit board and other components
- 8) Project board, serves as the basis for the construction of a circuit prototype
- 9) Male/female cable, serves as an electrical conductor to connect the electrical circuit
- 10) AC line cable, serves as a link between electrical equipment and an AC power source that comes from the PLN electricity network or an electric generator.

b. Literature Study

At this stage, researchers conduct literature reviews from various sources such as journals, books, and other sources related to this research.

c. Design of Props

Before entering the stage of designing/assembling the hardware components, researchers made a software design first to see the schematic design using the Proteus application. The design in the Proteus application is as shown below.

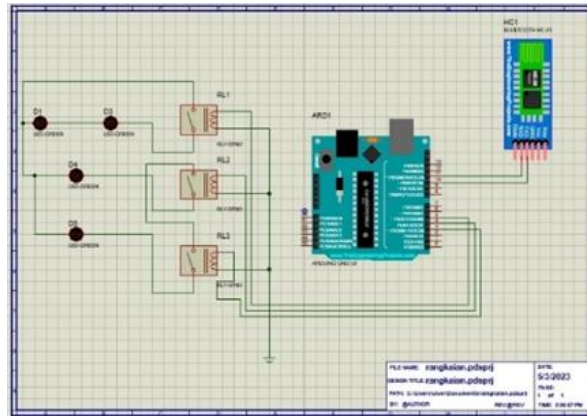

Figure 2. Design layout in proteus application

In this Proteus application, there are several component deficiencies such as the unavailability of a 4-channel relay module, so you have to use relay modules one by one. Then for the Bluetooth HC-05 module, there is already a library installed in the proteus application, but because there are still some limitations in connecting the wire/cable, then here for the temporary design can only connect two wires.

After making the design of the tool design in the proteus application, the next step is to make a schematic design of the components used assembled into one as shown below.

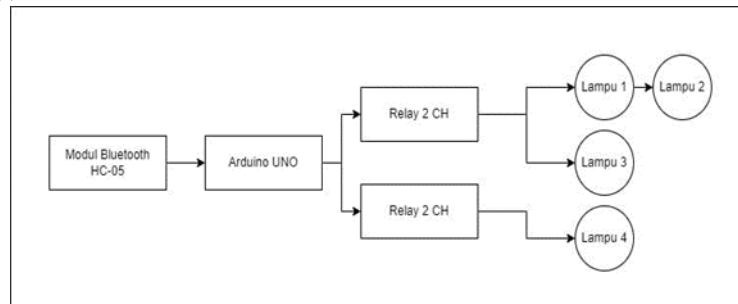

Figure 3. Schematic design of automatic light control system

After the schematic design has been made, the next step is to make a circuit design using the tools and materials as needed as shown below.

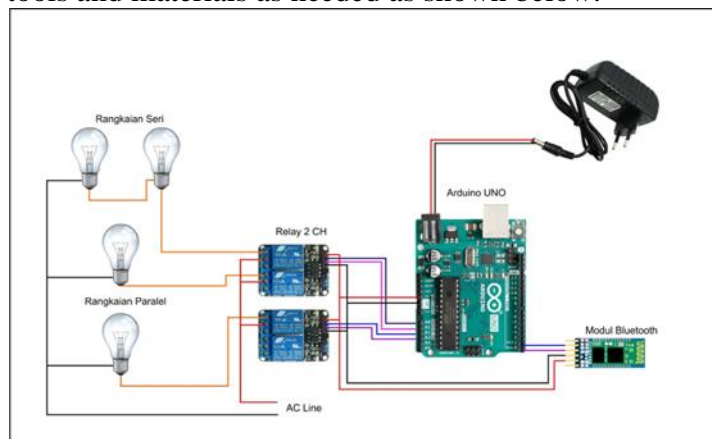

Figure 4. Design of the trainer circuit

d. Assembly of the Teaching Aid

At this stage, the components that have been prepared are then assembled according to the design that has been made. In addition, the automatic light control system program is made by creating a program listing on Arduino Uno using the Arduino IDE software and Proteus software to create a schematic design. Furthermore, the program listing that has been made is uploaded to the Arduino board so that the program can run.

e. Test of Props

At this stage, testing the program listing that has been made, then testing the Bluetooth connection to the smartphone, and after that testing the circuit. In the Arduino Bluetooth application on a smartphone, there is a display of several buttons used to turn on lights in series and parallel circuits. If button 1 is pressed, the series lights will appear to be lit or not lit. If button 2 is pressed, the parallel circuit on lamp 1 looks lit or not. Furthermore, if button 3 is pressed, the parallel circuit on lamp 2 looks lit or not. The test results will be shown in the following table:

Table 1. Observation Results

Testing	Circuit Lights	Testing Result	Remarks
Button 1	Series Lamp		
Button 2	Parallel Lamp 1		
Button 3	Parallel Lamp 2		

RESULTS & DISCUSSION

Results of the Teaching Aid

The Arduino uno-based automatic light control circuit as a basic physics teaching aid on Ohm's law using series and parallel electrical circuits is made based on Figures 1 and 2. At this stage, the product is made in the form of a board as a lamp holder with a description of the lights in series or parallel as in Figure 3. The use of smartphones functions as an automatic light control with the Arduino Bluetooth 4 CH application. Arduino Bluetooth 4 CH is an application on an Android smartphone that functions to control the lights that are assisted by the Bluetooth HC-05 module.

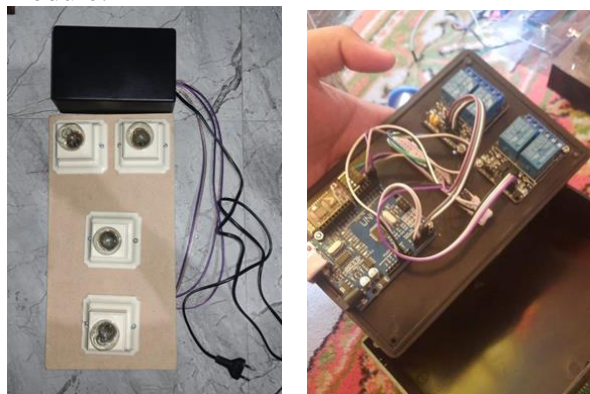

Figure 5. Props circuit board

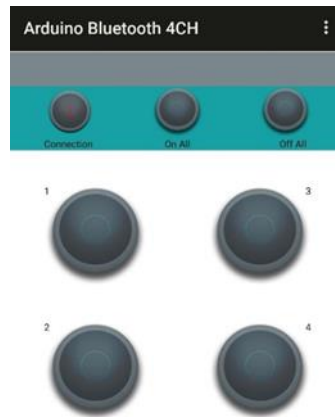

Figure 6. Bluetooth 4 CH app view

Then, the program listing uploaded to the Arduino board which is adjusted to the design of the props circuit in Figure 2 can be written as follows.

```
#define lampu1 A0
#define lampu2 A1
#define lampu3 A2
#define lampu4 A3

// Parameters for Bluetooth interface
char incoming;

void setup() {
  // put your setup code here, to run once:
  Serial.begin(9600);

  pinMode(lampu1, OUTPUT);
  pinMode(lampu2, OUTPUT);
  pinMode(lampu3, OUTPUT);
  pinMode(lampu4, OUTPUT);

  digitalWrite(lampu1, HIGH);
  digitalWrite(lampu2, HIGH);
  digitalWrite(lampu3, HIGH);
  digitalWrite(lampu4, HIGH);

  Serial.println("The device started, now you can pair
it with bluetooth!");
}

void loop() {
  // put your main code here, to run repeatedly:
```

```
if (Serial.available())
{
    incoming = Serial.read(); //Read what we receive

    // separate button ID from button value -> button ID
    // is 10, 20, 30, etc, value is 1 or 0
    // int button = floor(incoming / 10);
    // int value = incoming % 10;

    Serial.println(incoming);

    switch (incoming) {
        case '1':
            digitalWrite(lampu1, LOW);
            break;
        case 'A':
            digitalWrite(lampu1, HIGH);
            break;

        case '2':
            digitalWrite(lampu2, LOW);
            break;
        case 'B':
            digitalWrite(lampu2, HIGH);
            break;

        case '3':
            digitalWrite(lampu3, LOW);
            break;
        case 'C':
            digitalWrite(lampu3, HIGH);
            break;

        case '4':
            digitalWrite(lampu4, LOW);
            break;
        case 'D':
            digitalWrite(lampu4, HIGH);
            break;

        case '9':
            digitalWrite(lampu1, LOW);
            digitalWrite(lampu2, LOW);
            digitalWrite(lampu3, LOW);
            digitalWrite(lampu4, LOW);
            break;
        case 'I':
```

```
digitalWrite(lampu1, HIGH);
digitalWrite(lampu2, HIGH);
digitalWrite(lampu3, HIGH);
digitalWrite(lampu4, HIGH);
break;
```

Tool Test Results

The results of testing the Arduino Uno-based automatic light control tool as a basic physics teaching aid on Ohm's law are shown in table 2 and figure 4. Based on testing the lights are successfully controlled with the 4 CH Bluetooth application using an android smartphone. Lights with a series circuit will light up if button 1 is pressed. Lights with parallel circuit 1 will turn on if button 2 is pressed. Lights with parallel circuit 2 will light up if button 3 is pressed.

Table 2. Observation Results

Testing	Circuit Lights	Testing Result	Remarks
Button 1	Series Lamp	Lit	Work
Button 2	Parallel Lamp 1	Lit	Work
Button 3	Parallel Lamp 2	Lit	Work

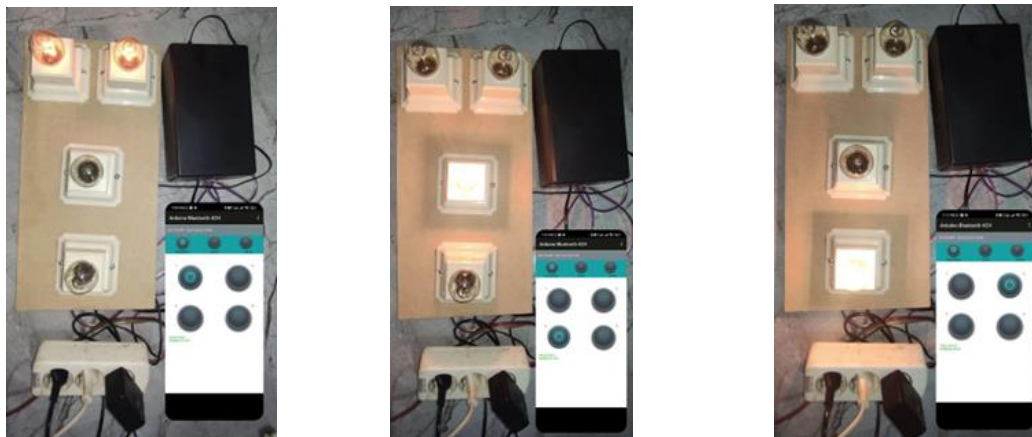

a. series lights turn on if pressing button 1 b. parallel 1 light turns on when pressing button 1 c. parallel 2 light turns on when pressing button 2

Figure 7. Props Test Result

Based on the test results of this props, it can be seen that all lights can be lit normally, with the information that the lights assembled in series are dimmer than the lights assembled in parallel (brighter). There are 2 lights connected in series and 2 lights connected in parallel. In the series circuit the lights can be turned on simultaneously while in the parallel circuit the lights are turned on alternately according to the program listing commands that have been set and by pressing different buttons on the bluetooth 4 CH application on android.

Discussion

Ohm's Law discusses the relationship between electric current, resistance, and voltage. Before understanding the relationship between these two physical quantities, it is necessary to know the definition of electric current and voltage. An electric current is a moving electric charge, but not all moving charges are electric

currents. It is said to be an electric current if the net electric charge flows through a part of the moving charge [10]. Voltage is a measure of the potential difference between two points in the electrical circuit. Voltage can also be interpreted as the amount of energy required to move electric charge from one location to another. The unit of electrical voltage is Volt or Voltage (V) (Hanafiah, 2023). The use of props in Ohm's law circuits can be used to improve understanding of existing material concepts. The existence of teaching aids can help clarify an abstract physics concept with a deeper understanding during direct learning.

The Arduino uno-based automatic light control circuit can be used as a basic physics teaching aid for Ohm's law material. In this teaching aid, there are two kinds of circuits, namely series circuits and parallel circuits. To run the circuit, a program listing is needed on Arduino Uno using Arduino IDE software and Proteus software to create a schematic design. This trainer uses 4 lights that are assembled in series and parallel. In addition, this prop is accompanied by Bluetooth to connect with a smartphone that functions as a medium to control automatic lights with the Arduino bluetooth 4 CH application. This Ohm's law teaching aid is designed to be as easy as possible so that users can easily operate it as a learning medium.

On the smartphone screen display, there will be 4 buttons that are used to turn on the lights according to the program's listening commands. Based on the test results, it can be seen that if you press the first button on the top left, the lights in the series circuit will turn on with a dim light intensity, while if you press the second button on the top right and the third button on the bottom left, the lights in the series circuit will turn on alternately with bright light intensity. So, it can be said that the lights can turn on normally only differentiated by the intensity of light produced by the type of circuit. Therefore, it can be concluded that the circuit can affect the intensity of light produced by the lamp. This Ohm's Law automatic light trainer is made so that users can find out how to combine Ohm's Law material with Arduino uno as a media system. In addition, this tool can also be used to train the thinking and analysis skills of users, especially students who are learning about electrical material.

CONCLUSION

Ohm's law discusses the relationship between electric current, resistance, and voltage. The implementation of Ohm's law can be associated with the microcontroller on the Arduino UNO. The design of Ohm's law props based on Arduino UNO with series and parallel circuits has been successfully made and used. In this props can be connected to a smartphone to control the lights automatically using Bluetooth. In addition, the program listing has an important role so that this series-parallel light circuit can be operated properly. In addition, the series of lights made can light up normally but have different light intensities. It is hoped that this teaching aid can facilitate students who are taking basic physics. As for suggestions for the development of this Arduino-based Ohm's Law teaching aid, you can add the number of lights to make it more varied.

ACKNOWLEDGEMENT

We would like to thank Mr. Alex Harijanto and Mr. Subiki for their contributions that have guided researchers in this research, so that it can produce a work in the form of automatic light props.

REFERENCES

- Aslam, A., Syamsu, S., & Darsikin, D. (2016). Pengembangan Alat Praktikum Hukum Ohm Berbasis Grafik Menggunakan Mikrokontroler Pada Mahasiswa Calon Guru Fisika. *JPFT (Jurnal Pendidikan Fisika Tadulako Online)*, 4(1), 20. <https://doi.org/10.22487/j25805924.2016.v4.i1.5479>
- Djarmiko, W. (2017). Prototipe Resistansi Meter Digital. *Jurnal Semianr Nasional Sains Dan Teknologi*, 1(18), 1–8. <https://jurnal.umj.ac.id/index.php/semnastek/article/view/1905/1558>
- Hanafiah, A. M. (2023). Komparasi Konsumsi Energi Listrik Pada Motor Listrik Di HAR Unit 4 PT . Indonesia Power Suralaya. *Jurnal Teknik Mesin, Industri, Elektro Dan Informatika (JTMEI)*, 2(1).
- Kadir. (2013). *Panduan Praktis Mempelajari Aplikasi Mikrokontroler dan Pemogramannya menggunakan Arduino* (Issue December).
- Kurniadi, D., & Fitriyani, F. (2015). Sistem Kendali Jarak Jauh Perangkat Elektronik Rumah Berbasis Cloud Computing. *Jurnal Algoritma*, 14(2), 333–342. <https://doi.org/10.33364/algoritma/v.14-2.333>
- Muchlis, F., & Toifur, M. (2017). Rancang Bangun Prototype Media Pembelajaran Fisika Berbasis Micro Controller NodeMCU. *Jurnal Riset Dan Kajian Pendidikan Fisika*, 4(1), 12. <https://doi.org/10.12928/jrkpf.v4i1.6464>
- Nuvitalia, D., Patonah, S., Saptaningrum, E., Khumaedi, & Rusilowati, A. (2016). Analisis Kebutuhan Alat Peraga Dalam Implementasi Kurikulum 2013 Pada Mata Pelajaran Ipa Terpadu. *Upej*, 5(2), 60–65. <http://journal.unnes.ac.id/sju/index.php/upej>
- Qomariyah, N., Wirawan, R., Minardi, S., Alaa', S., & Yudi Handayana, I. G. N. (2020). Pendalaman Konsep Fisika Menggunakan Alat Peraga Berbasis Mikrokontroler Pada Siswa Sma. *SELAPARANG Jurnal Pengabdian Masyarakat Berkemajuan*, 4(1), 486. <https://doi.org/10.31764/jpmb.v4i1.3225>
- Saefullah, A., Fakhurrokhman, M., Oktarisa, Y., Arsy, R. D., Rosdiana, H., Gustiono, V., & Indriyanto, S. (2018). Rancang Bangun Alat Praktikum Hukum Ohm Untuk Memfasilitasi Kemampuan Berfikir Tingkat Tinggi (Higher Order Thinking Skills). *Gravity : Jurnal Ilmiah Penelitian Dan Pembelajaran Fisika*, 4(2), 81–90. <https://doi.org/10.30870/gravity.v4i2.4035>
- Subekti, Y., & Ariswan, A. (2016). Pembelajaran fisika dengan metode eksperimen untuk meningkatkan hasil belajar kognitif dan keterampilan proses sains. *Jurnal Inovasi Pendidikan IPA*, 2(2), 252. <https://doi.org/10.21831/jipi.v2i2.6278>
- Susanti, H., & Asmoro, C. P. (2019). ISSN: 2338-1027 Februari 2019 REKONSTRUKSI SET ALAT PERCOBAAN VISKOSITAS. *Jurnal Wahana Pendidikan Fisika*, 4(1), 31–36.
- Widiyatmoko, A., & Pamelasari, S. D. (2012). Pembelajaran berbasis proyek untuk mengembangkan ALAT peraga IPA dengan memanfaatkan bahan bekas pakai. *Jurnal Pendidikan IPA Indonesia*, 1(1), 51–56. <https://doi.org/10.15294/v1i1.2013>